

Respect Excellence
Integrity Leadership



Modernizing Procurement in the Government of Canada

Presentation to the Ontario Institute of the Purchasing Management Association of Canada

By Marcel Chiasson, Director General, Procurement Renewal Office, Public Works and Government Services Canada

October 23, 2009

 Public Works and Government Services Canada  Travaux publics et Services gouvernementaux Canada



Respect - Integrity - Excellence - Leadership

Purpose

- Overview of Canada's Public Sector Procurement and Drivers to Procurement Renewal
- Present the Procurement Renewal Initiative and our Implementation Strategy
- Priorities for Modernization

 Public Works and Government Services Canada  Travaux publics et Services gouvernementaux Canada



2

Background

Contracting in Government of Canada

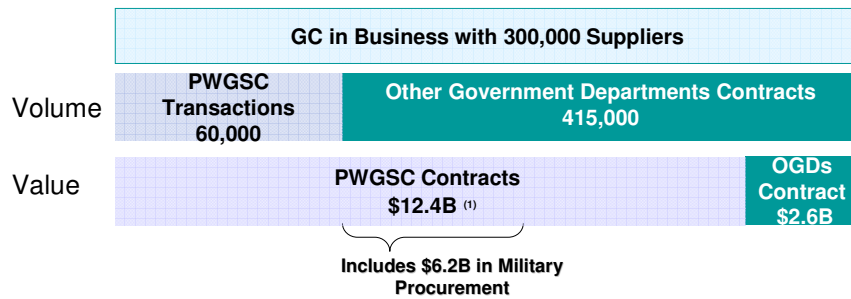

(1) Based on 3 year average 2005-2008

Balancing Competing Interests for the Public Good

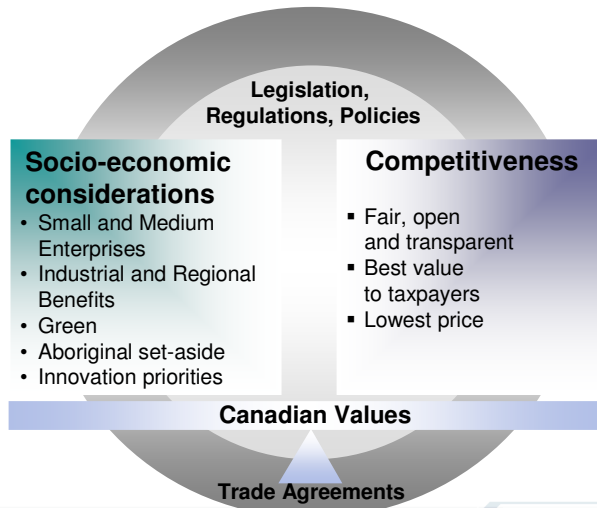

The Drivers to Renewal

Speech from the Throne
November 2008

“Fixing procurement will be a top priority. Simpler and streamlined processes will make it easier for businesses to provide products and services to the government and will deliver better results for Canadians.”

Stakeholder views
opportunities for improvement

Suppliers' views:

- Hard to do business with Government of Canada
- Processes are too complex/bureaucratic
- Perceived unfairness/restricted access
- Government is too risk averse

Departments' views:

- Would like more e-tools/easy-to-use/self-serve
- Processes are too complex
- Departments seeking flexibility/better balance with respect to risk



Public Works and
Government Services
Canada

Travaux publics et
Services gouvernementaux
Canada

Canada

5

Procurement Renewal Implementation Plan

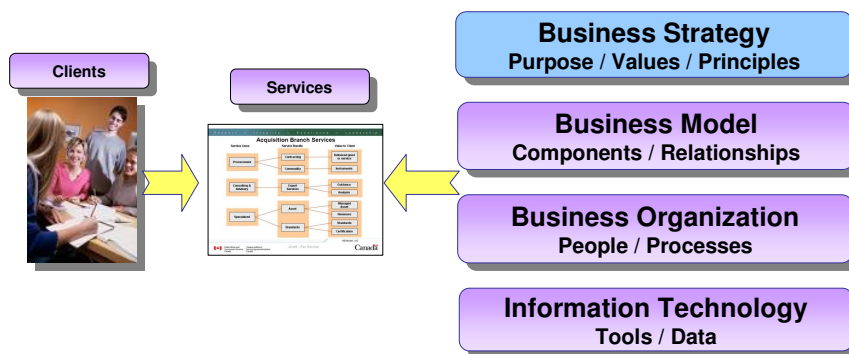

Public Works and
Government Services
Canada

Travaux publics et
Services gouvernementaux
Canada

Canada

6

Business Strategy

Our Goal is to develop a highly efficient and streamlined procurement function to acquire goods and services as quickly as possible, at the best price for the Crown while respecting the government's socio-economic objectives.

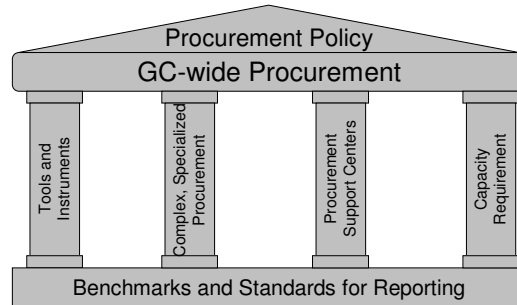

Procurement Program Policy

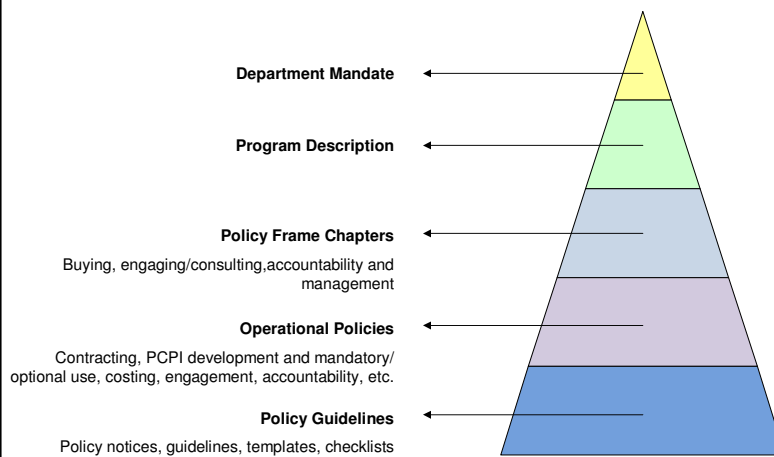

Procurement Renewal Implementation Plan

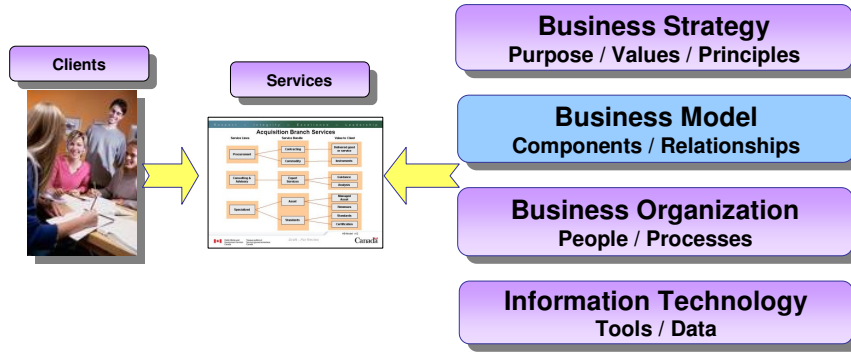

Business Model Components

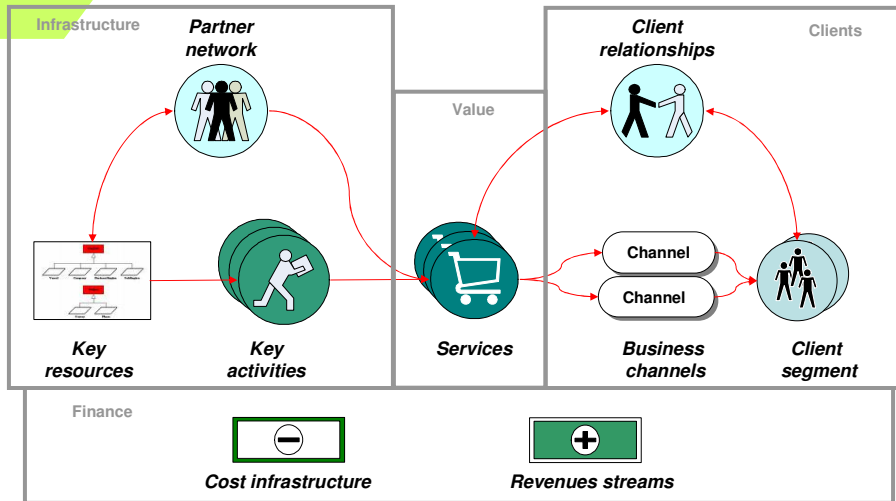

Procurement Renewal Implementation Plan

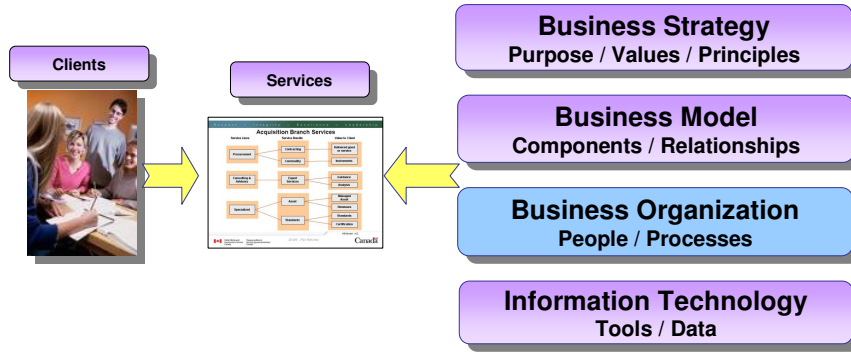

Business Organization

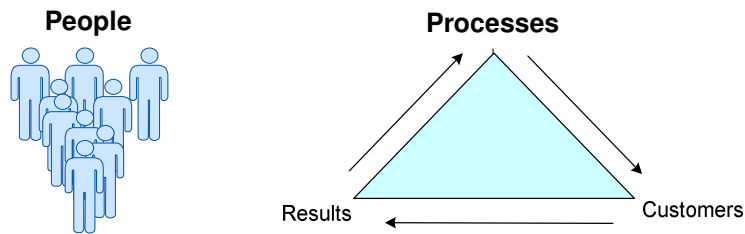

People Management

- Organizational alignment and a sense of common purpose around renewal
- Promote and encourage employee involvement in the strategic and implementation aspects of Procurement Renewal

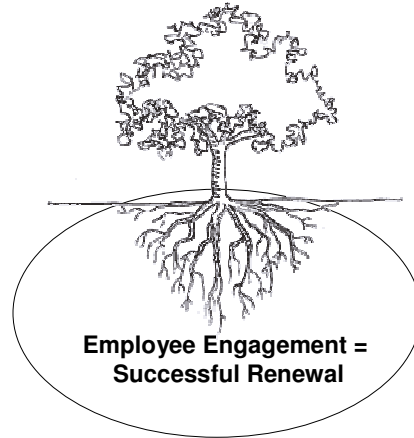

Business Process Management Conceptual Framework

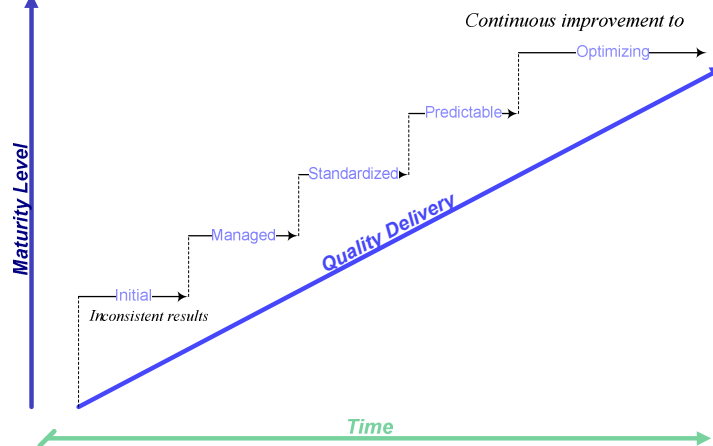

Procurement Solution Modernization

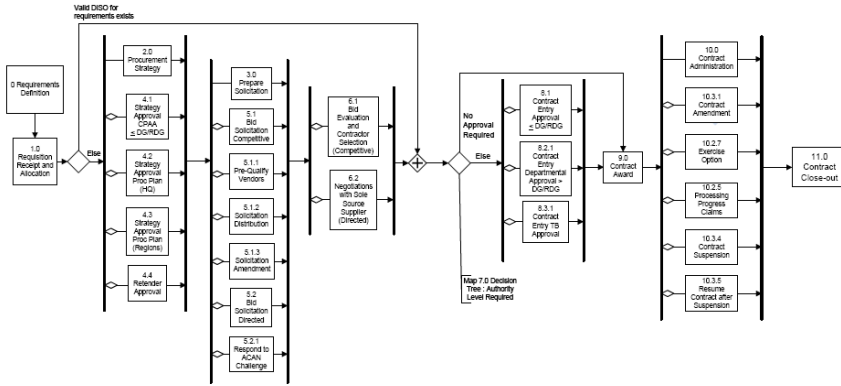

New Service Discipline

Based on Dynamic Baseline Procurement Classification

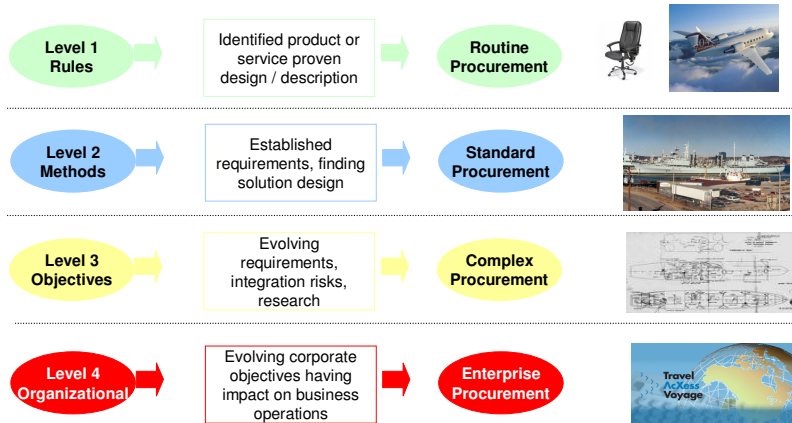

Procurement Renewal Implementation Plan

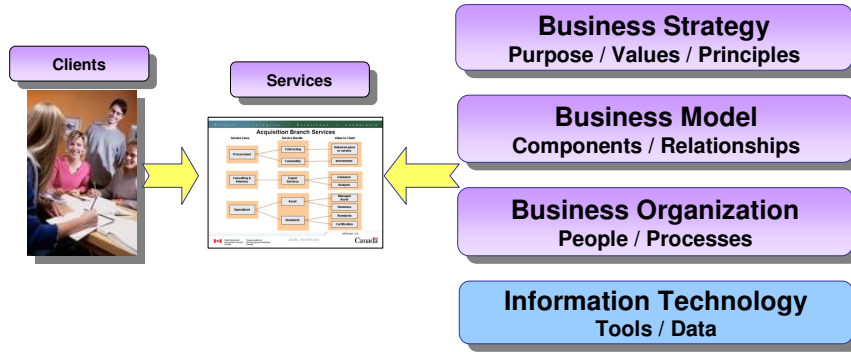

Information Technology

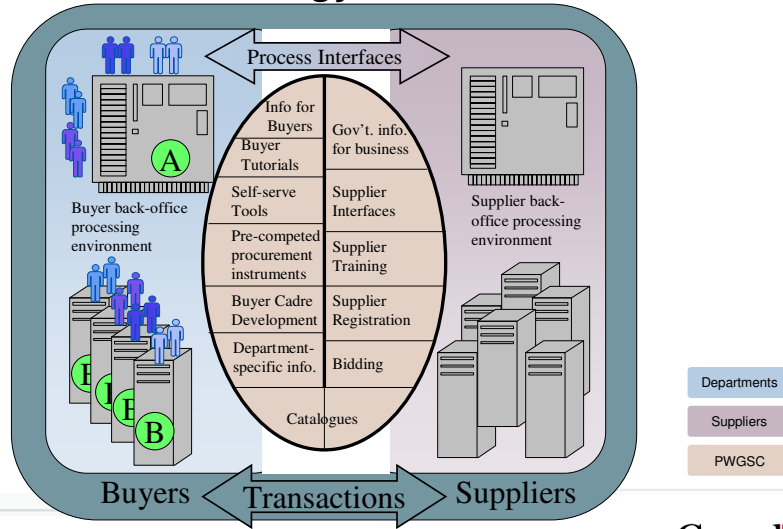

Procurement Web Presence

Providing a common and user-friendly interface for suppliers to do business with us and for departments to find the information they need to buy.

2009-10 Priorities for Modernization

